

Product Selection Guide

EDM (Engineering Data Management) Selection Guide

EDM is the PC software that supports CoCo-80/90, Spider and with post processing functions. EDM has four working modes:

- **CoCo-80 DSA mode:** accesses CoCo-80 in its DSA mode, download files and view data files. CSA Editor, a tool of editing CoCo testing projects, will be included in this mode.
- **CoCo-80 VDC mode:** creates route data collection database, upload settings to CoCo, download data to PC, trending and alarm analysis. There are two versions of VDC modes: personal version allows the user access the database on his local PC. Enterprise version allows multiple user access the database on the LAN.
- **Spider Real-Time Mode:** operates on Spider hardware in real-time
- **Post Analysis Mode:** analyzes the data files on PC using various algorithms. PA has three versions: PA Viewer allows the user to view the data and create report; PA Basic has FFT spectral analysis and 3D signal display functions; PA Premium has all post analysis functions.

The basic structure of EDM is:

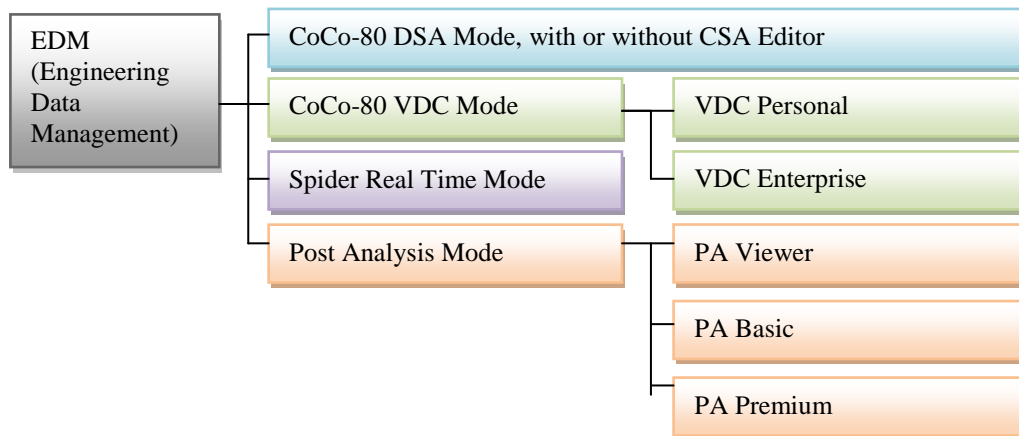

EDM software is registered to a CoCo or a Spider device. To activate the EDM software, the user must have a License Key.

EDM Post Analysis (PA) Functions

There are three versions of Post Analysis functions, PA Viewer, PA Basic and PA Premium. The function comparison is listed below:

Functions	PA Viewer	PA Basic	PA Premium
Browse, display and edit long waveform files	√	√	√
Signal display with different spectrum unit and X-Y scale	√	√	√
Signal annotation, cursor, play sound, calculate RMS, THD, ZOOM-in, ZOOM-out, auto scaling	√	√	√
Create template-based report in HTML, Excel, Word or PDF	√	√	√
Engineering unit conversion, dB reference	√	√	√
Export to standard formats including ASAM-ODS, UFF, BUFF, MATLAB, TDM, user-defined ASCII and wave files	√	√	√
Import user-defined ASCII file, wave file, Pacific Instrument file		√	√
Acceleration, velocity and displacement conversion		√	√
FFT Spectral analysis: FFT, auto power spectra, cross power spectra, frequency response function		√	√
3D display: waterfall, color map		√	√
Math Functions: abs, +, -, *, /, square, square-root, log, integration, differentiation, RMS, peak, offset and scale,			√
Digital Filters: IIR, FIR, Low-pass, High-pass, Band-pass			√
User defined data conditioning modules			√
Fractional octave filters: 1/1, 1/3, 1/6, 1/12			√
Order Tracking: RPM spectra, order spectra			√
Polynomial Curve Fit			√
Data file batch processing			√

CoCo-80/90 Selection Guide

This section describes the different members of the CoCo product family. Please refer to Table 1 for a detailed comparison of the products.

CoCo-80

CoCo-80 is the main product in the CoCo family and is the best choice for most applications. It is equipped with either 2, 4 or 8 BNC connector input channels. The inputs have IEPE, single-end and differential mode and 130 dB dynamic range.

When a 2-channel system is ordered, a 4-input system will be shipped but 2 inputs are disabled in the software. The user can enable the two additional inputs by purchasing a software key for additional input channels.

The 4-channel CoCo-80 can be upgraded to 8-channels at the CI factory.

Channel 1 can be configured as a tachometer input. The mass flash memory of CoCo-80 can record 1~8 channels of streaming signals simultaneously up to 102.4 kHz with real-time spectral analysis capability.

CoCo-90

CoCo-90 has a higher channel count and is a good choice for monitoring more than 8 channels simultaneously. It has 16 SMB connector input channels. The inputs have IEPE and single-end input mode, 100 dB input dynamic range and three input range settings. Differential input mode is not available on CoCo-90. CoCo-90 has a separate tachometer input and channel 1 can also be configured as a second tachometer input. All input channels can be simultaneously sampled up to 102.4 kHz. The continuous recording speed is limited to 51.2 kHz per channel for simultaneous 16 channel recording. CoCo-90 does not run the Vibration Data Collector working mode.

The CoCo-80 and CoCo-90 enclosures are identical in size. Note that the CoCo-80 and CoCo-90 cannot be upgraded to each other. CoCo-80 can be upgraded from 2 to 4, or 4 to 8 channels. All versions have a signal source output channel and the same computer connection peripherals.



■ Figure 1 CoCo-80 with 4 BNC input connectors and an output source channel. (2 input channels can be disabled in software to reduce the purchasing cost).



■ Figure 2 CoCo-80 with 8 BNC input connectors and an output source channel.



■ Figure 3 CoCo-90 with 16 SMB input connectors plus a tachometer and output source channel.

Table 1. Product Selection Guide

		CoCo-80	CoCo-90
Number of Input Channels		2, 4 or 8	16
Input dynamic range		130 dB One input range (10V or 20V)	100 dB Three input ranges (10V, 1V, 0.1V)
Input Mode		IEPE AC-Differential DC-Differential AC-Single End DC-Single End	IEPE AC-Single End DC-Single End
Input connector type		BNC, isolated	SMB
Dynamic Signal Analyzer Mode	Long time recording, transient capture, auto-power spectra, cross spectra, FRF and Coherence	Yes	Yes
	Classic waveform signal source	Yes	Yes
	Data Conditioning (math operation for time streams)	Yes	Yes
	Flexible Configurable Signal Analysis	Yes	Yes
	Octave and SLM (CoCo-P11)	Yes	Yes (runs on 8 inputs or less)
	Order Tracking (CoCo-P12)	Yes	Yes (runs on 8 inputs or less)
	Swept Sine (CoCo-P13)	Yes	Yes
	Arbitrary Waveform Signal Source (CoCo-P14)	Yes	Yes
	Automated Limit Test (CoCo-P15)	Yes	Yes
	Real-Time Digital Filters (CoCo-P16)	Yes	Yes
	Histogram and Statistics (CoCo-P17)	Yes	Yes
Vibration Data Collector Mode	Vibration Data Collection, Waveform, Spectrum, Overall, Alarm, Trending, Balancing (CoCo-Pxx)	Yes (runs on 4 inputs or less)	N/A
Hardware Upgradability		4ch system can be upgraded to 8ch at factory. Cannot upgrade to CoCo-90	No upgrade
Order Part Number		CoCo-P04 for 2 ch. CoCo-P01 for 4 ch.; CoCo-P02 for 8 ch.	CoCo-P03

CoCo-80/90 Application Software Function Map

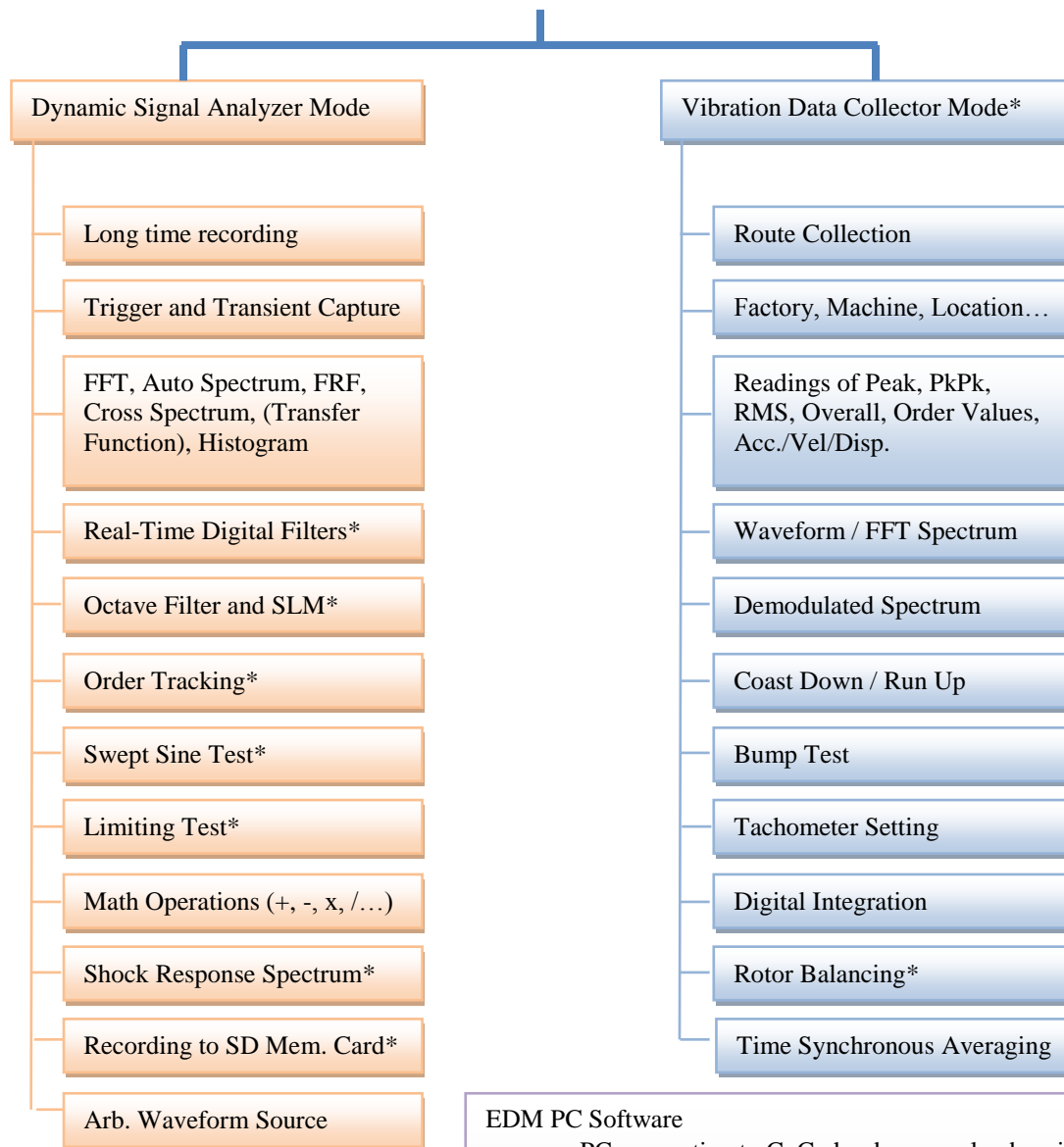

EDM PC Software

- PC connection to CoCo hardware, upload project and download data files
- Display, cursors, and annotations
- Template based reporting
- Browse and display long waveform files
- Modal data interface
- File export to: UFF, UFFB, ASCII, XLS, WAV, NI-TDM, MatLab
- Data post processing (FFT spectral analysis, math, digital filter, octave, order tracking)
- Vibration Data Collector functions (route collection, trending, alarm and database synchronization with CoCo hardware)

* Software options with extra charges.